

**LEISTER**

# LE MINI SENSOR KIT



Leister Process Technologies  
Riedstrasse  
CH-6060 Sarnen/Switzerland

Tel. +41-41662 74 74

Fax +41-41662 74 16

[www.leister.com](http://www.leister.com)  
[sales@leister.com](mailto:sales@leister.com)





## WARNUNG



**Danger!** When opening up the tool, live components and connections are exposed. Therefore, before opening it, unplug the tool to ensure disconnection from the mains.



Incorrect use of hot air tools can present a **fire and explosion hazard**, particularly in the proximity of flammable materials and explosive gases.



**Danger of getting burned!** Do not touch the end of the element holder and nozzle when they are hot. Let the tool cool down. Do not point the hot air flow in the direction of people or animals.



## CAUTION



The **rated voltage** stated on the tool must correspond with the mains voltage.



The tool must be operated **under supervision**. Heat can ignite flammable materials which are not in view.



Protect the tool **from damp and wet**.

Electrical safety:  **double insulated**

## TECHNICAL DATA

Voltage	V~	230	120
Frequency	Hz	50 / 60	50 / 60
Power consumption	W	800	400
Max. temperature	°C / °F	750 / 1382	600 / 1112
Max. ambient temperature	°C / °F	60 / 140	60 / 140
Min. air flow	l/min	10	10
Max. pressure	Pa	2×10 <sup>5</sup>	2×10 <sup>5</sup>
Thermal switch for tool protection		+	+
Heating element protection		+	+
Integrated heating probe		+	+
Integrated temperature regulator		+	+
Weight heater LE MINI SENSOR	g	330	330
Weight connection box	g	2150	2150
Dimensions, heater LE MINI SENSOR	mm	308 × 27	253 × 27
Dimensions, heating tube ø	mm	15	15
Screwed nozzle joint		G 1/4" × 8	G 1/4" × 8
Dimensions, connection box L×B×H	mm	240 × 160 × 120	240 × 160 × 120
Fuse	A	6.3 AT	6.3 AT

**OPERATION**

**LE MINI SENSOR KIT**

**Tool description**

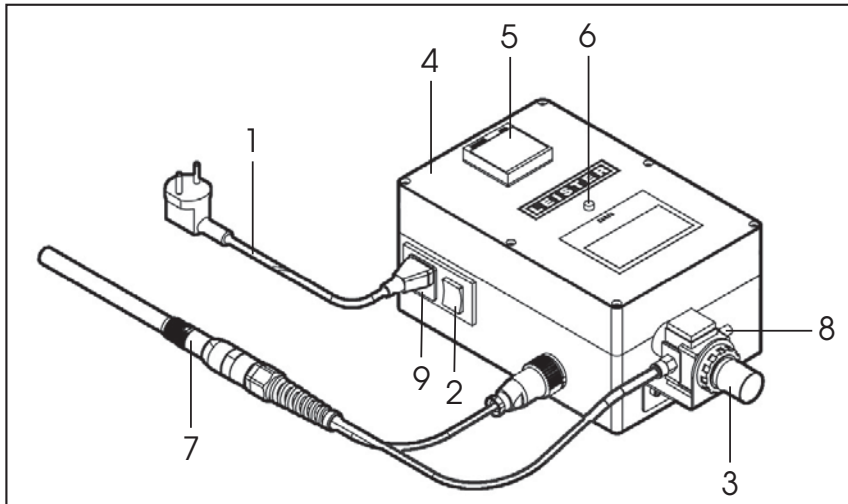

1. Power supply cord
2. Main switch
3. Pressure reduction valve
4. Connection box
5. Temperature regulator CSS
6. Fault indicator
7. Heater LE MINI SENSOR
8. Compressed air connection
9. Fuseholder

**Connection diagram**

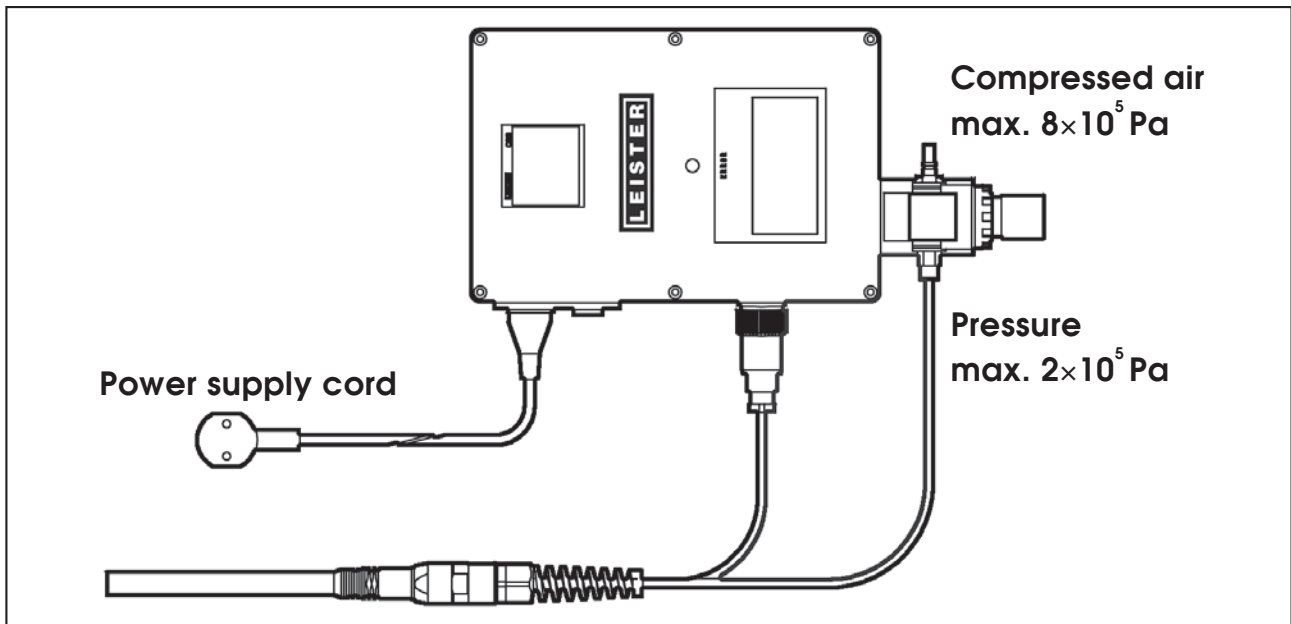

**Assembly dimensions in mm**

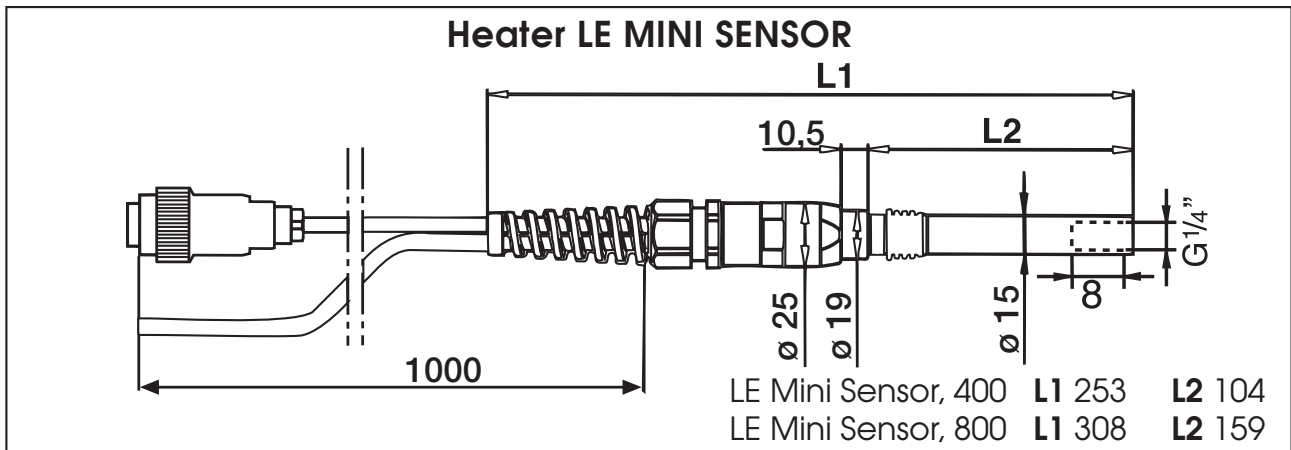

## OPERATION

## LE MINI SENSOR KIT

### Assembling

- Assembly must ensure that:
  - only cold air is supplied
  - no (hot air) backup occurs
  - the tool is not subjected to a hot air flow from another tool
- The tool is protected against mechanical vibration and shaking
- No air blasts at temperatures over 100°C

### Air supply

- If compressed air is used, an upstream oil and water separator must be connected.
- The tool must only be supplied with air up to a max. 60°C.

### Betrieb

- The tool must be connected by a qualified electrician in accordance with the circuit diagram on page 3.
- Fit the nozzle appropriate to the use.
- Connect the air supply at the **compressed air connection (8)**.
- Set the air flow at the **pressure reduction valve (3)** (min. air flow, max. pressure - see technical data page 2)
- Switch on at **main switch (2)**
- Set the required hot air temperature at the **temperature regulator CSS (5)**.
- After use let the tool cool down by allowing cold air to flow through (avoiding a build up of heat).

**Attention: Never operate tool without air supply!**

### Function heat element protection

- If the heating element overheats, the heater is switched off through the converter integrated in the **connection box (4)**. The shutdown is indicated on the **fault indicator (6)**.

### Function tool protection

- If the tool overheats, the heater is switched off through the converter integrated in the **connection box (4)**. The shutdown is indicated on the **fault indicator (6)**.

### Measures to take in the case of switching off through the heating element protection and tool protection

- Switch off the tool at the **main switch (2)**
- Check the compressed air
- Check the air flow rate
- Check the through flow of air
- Switch on the tool at the **main switch (2)**

## CONFORMITY

## LE MINI SENSOR KIT

**Leister Process Technologies, Riedstrasse, CH-6060 Sarnen/Schweiz** confirms that this product, in the version as brought into circulation through us, fulfils the requirements of the following EC directives. Directives: 89/336/EEC, 73/23/EEC. Harmonized Standards: EN 55014-1, EN 55014-2, EN 61000-3-2, EN 61000-3-3, EN 60335-2-45.6060

Sarnen, 09.06.2006



Christiane Leister, Firmeninhaberin

## DISPOSAL



Power tools, accessories and packaging should be sorted for environmental-friendly recycling. Only for EC countries: Do not dispose of power tools into household waste! According to the European Directive 2002/96/EC on waste electrical and electronic equipment and its incorporation into national law, power tools that are no longer suitable for use must be separately collected and sent for recovery in an environmental-friendly manner.

## TRAINING

LEISTER Process Technologies and its authorised Service Centres offer free of charge courses in the range of applications on page 1.

## ACCESSORIES

- Only LEISTER accessories should be used.
- Let the tool cool down before changing the nozzle or reflector

## SERVICE AND REPAIR

- Repairs should only be carried out by authorised **LEISTER Service Centres**. They guarantee a correct and reliable **repair service within 24 hours** using original spare parts in accordance with the circuit diagrams and spare parts lists.

## WARRANTY

- For this tool, we generally provide a warranty of one (1) year from the date of purchase (verified by invoice or delivery document). Damage that has occurred will be corrected by replacement or repair. Heating elements are excluded from this warranty.
- Additional claims shall be excluded, subject to statutory regulations.
- Damage caused by normal wear, overloading or improper handling is excluded from the guarantee.
- Guarantee claims will be rejected for tools that have been altered or changed by the purchaser.

**Technical data and specifications are subject to change without prior notice.**