

LEISTER

PROCESS HEAT

Hot air blower
HOTWIND PREMIUM
HOTWIND SYSTEM



New!

The new HOTWIND PREMIUM and HOTWIND SYSTEM from Leister

The new HOTWIND PREMIUM is the successor to the hugely popular HOTWIND S. Its brushless motor ensures that this hot air blower has a long service life. The maximum air volume can now be set infinitely up to 900 l/min via the potentiometer.

The wide range of applications makes the new HOTWIND SYSTEM truly impressive: be it as a unit with integrated control or as a unit for integration in a closed loop control circuit using a system interface.

Advantages



1		Infinitely adjustable: Potentiometers for stepless adjustment of the heating and blower (PREMIUM and SYSTEM).
2		Remote controlled: Interface with alarm contact in the HOTWIND SYSTEM for controlling the air volume and heat output, using 4 – 20 [mA] or 0 – 10 [V] signal.
3		Integrated: Temperature probe in the HOTWIND SYSTEM for even greater precision.
4		User friendly: Display on the HOTWIND SYSTEM provides the user with status information.
5		Cleverly combined: Main switch with integral function button for programming (SYSTEM).
6		Cool: The unit is automatically cooled prior to switching off by pressing the function button.

Technical features

	PREMIUM	SYSTEM
Heat output and air volume steplessly adjustable with potentiometer	•	•
Integrated power electronics	•	•
Protection against heating element or device overheating	•	•
Brushless blower motor	•	•
Alarm output		•
Integrated temperature control		•
Remote control interface for temperature or power set point		•
Remote control interface for air volume adjustment		•
Integrated temperature probe		•
Display for showing the setpoint and actual values (°C or °F)		•

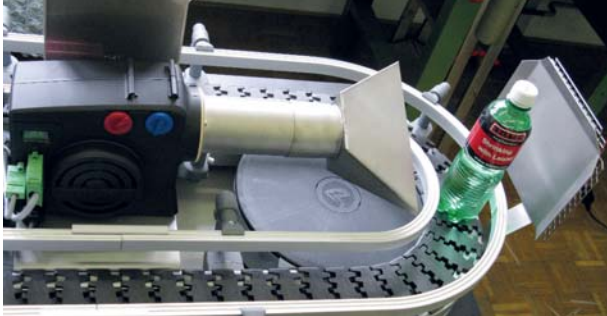

HOTWIND SYSTEM with wide slot nozzle integrated in a blow-off application.



HOTWIND SYSTEM as hot air provider in a shrinking process.

Technical data

Voltage	V~	120	230	230	230	230	230	400
Power consumption	W	2300	2300	2300	3100	3700	3700	5400
Frequency	Hz	50/60						
Max. air outlet temperature	°C	650	650	650	800	650	650	650
Max. air flow (20 °C)	l/min.	200 – 900						
Static pressure	Pa	500						
Noise emission	L _{pA} (dB)	< 70						
Weight without cable	kg	2.6						
Measure		see below						
Mark of conformity		CE						
Certification scheme		CCA						
Protection classe II		□						
Without connecting plug		•		•			•	•
Connecting plug (Euro)			•		•	•		
Art. No. PREMIUM		140.095	142.612	142.643	142.608	142.609	140.098	follows
Art. No. SYSTEM		142.636	142.646	140.096		142.645	142.640	follows

Subject to change without notice
Connection voltage non-switchable

Additional versions on request

Accessories HOTWIND

107.262		Wide slot nozzle, push-fit, 300 × 4 mm (Other sizes available)
105.919		Tubular nozzle, push-fit, 456 × 306 × 3 mm (Other sizes available)
107.329		Sieve reflector, push-fit, 76 × 75 mm (Other sizes available)
106.174		Shell reflector, push-fit, 400 × 65 mm (Other sizes available)
107.245		Round nozzle, push-fit, Ø 40 mm (Other sizes available)
107.335		Sieve reflector, push-fit, Ø 150 mm (Other sizes available)
141.723		Handtool-Kit (Handle and protective tube)
106.956		Thermocouple with plug, 1 m cable

Installation dimensions in mm

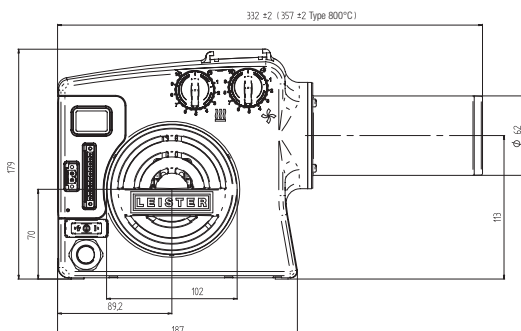
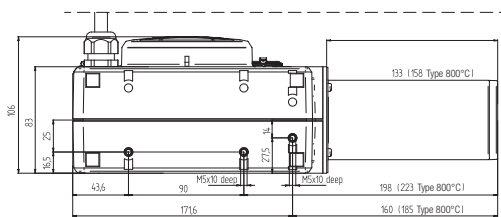

Application as a handheld or table unit with handle and protective tube.

Headquarters:

Leister Process Technologies
Galileo-Strasse 10
CH-6056 Kaegiswil/Switzerland
phone: +41 41 662 74 74
fax: +41 41 662 74 16
leister@leister.com
sales@leister.com

Leister Technologies LLC
1253 Hamilton Parkway
Itasca, IL 60143/USA
phone: +1 630 760 1000
fax: +1 630 760 1001
sales@leisterusa.com

Leister Technologies Ltd.
Building A, 1588 Zhuanxing Road
Shanghai 201 108 PRC
phone: +86 21 6442 2398
fax: +86 21 6442 2338
leister@leister.cn

Leister Technologis KK
Shinyokohama Bousei Bldg 1F
3-12-20, Shinyokohama, Kohoku-ku,
Yokohama 222-0033
phone: +81 (45) 477 3637
fax: +81 (45) 477 3638
sales-japan@leister.com

Our close worldwide network of more than 120 Sales and Service Centres in more than 90 countries.



Distributor Address:

Assembly Supplies, Co.
1250 Pacific Oaks Place #104
Escondido, CA 92029
Tel (800) 694-1472
Fax (888) 694-4275
Web www.hotairtools.com - e-mail info@hotairtools.com